

INTEGRITY DOUBLE HUNG (IDH) (DISCONTINUED – JANUARY 2006)

Table of Contents

	PAGE
Integrity Double Hung	
History	2
Parts	
Hardware	3
Miscellaneous Parts	5
Weather Strip and Vinyl Parts	6
Wood Parts	11
High Performance Kits	12
Balance Tubes	13
Sash Replacement	14
Grille Replacement	15
Screens and Screen Parts	16
Service	
Stationary Sash Removal	17
Stationary Sash Replacement	19
Balance Tube Replacement	20
Lock and Keeper Replacement	23
Tilt Latch and Cover Replacement	24
Sash Pivot Pin Replacement	25

NOTE: For double hung direct glazed transom information see Chapter 6 Round Top/Polygon.

ATTENTION:

- Specification and technical data are subject to change without notice.
- Numbers listed in parentheses () are metric equivalents in millimeters rounded to the nearest whole number.

PRODUCED	UNIT TYPE	FEATURES OR CHANGES	DISCONTINUED
1995	Double Hung	<p>April 1995: Integrity Double Hung introduced. Unit features 3/4" Low E II glass with Argon, 4 9/16" jambs.</p> <p>April 1995: Pultruded fiberglass (Ultrex) exterior available in white or pebble gray, almond frost sash lock and tilt latches, white or pebble gray exterior screen surround. Abbreviated IDH</p> <p>October: Changed check rail pile weather strip (white) from location at check rail to a continuous length (gray) from check rail to sill.</p>	<p>January 2006</p> <p>Arctic White – Feb. 2002</p> <p>February 1996</p>
1996	Double Hung	<p>January 1996: Tempered glass added as an option to certain size double hungs and picture units.</p> <p>February 1996: Vinyl trim added to the stiles of the bottom sash.</p> <p>February 1996: Clutch system upgraded to ensure positive locking during sash removal.</p> <p>October 1996: Introduced 5 5/16" and 6 13/16" jamb extension available shipped loose for field application.</p> <p>November 1996: Replaced jamb weather strip profile V167 with V169 and replaced bottom sash weather strip profile V161 with foam weather strip profile V189.</p> <p>November 1996: Replaced header hollow bulb weather strip with a parting stop.</p>	<p>Present</p> <p>November 1996</p> <p>Present</p> <p>December 2000</p> <p>October 2002</p> <p>Present</p>
1997	Double Hung	<p>March 1997: Added cottage style double hung and new IDHP 5648 picture size.</p> <p>September 1997: Introduced grilles-between-the-glass (GBG) simulated divided lite option.</p>	<p>Present</p> <p>Present</p>
1998	Double Hung	<p>May 1998: Sill/jamb plug redesigned.</p> <p>July 1998: Changed to a reinforced design tilt latch cover.</p> <p>November 1998: Introduced white hardware and screen option.</p>	<p>Present</p> <p>Present</p> <p>Present</p>
2000	Double Hung	<p>April 2000: Added 4 wide mulling option in CN 22 and CN26 widths available factory mulled. Added 2 wide – 2 high mulling option available factory mulled.</p> <p>December 2000: 6 13/16" jamb extension available factory applied. 5 5/16" jamb extension no longer available.</p>	<p>Present</p> <p>Present</p>
2001	Double Hung	<p>March 2001: Added white interior finish.</p>	<p>Present</p>
2002	Double Hung	<p>February 4, 2002: Stone White replacing Arctic White as a standard color. Arctic White replacement parts available through the warranty period.</p> <p>May 2002: New sizes available. Refer to Product bulletin #46.</p>	<p>Present</p> <p>Present</p>
2002	Double Hung	<p>October 2002: Revised bottom sash weather strip profile V189.</p> <p>October 2002: Revised jamb weather strip profile V169.</p>	<p>October 2002</p> <p>Present</p>
2003	Double Hung	<p>September 9, 2003: Replaced sill weather strip profile V191 with V1165.</p> <p>September 9, 2003: Replaced bottom sash weather strip V189 with V1232. V1194 bottom Jamb weather strip added in conjunction with current V169 weather strip at top.</p> <p>September 9, 2003: Replaced bottom sash weather strip V189 with V1232. V1194 bottom Jamb weather strip added in conjunction with current V169 weather strip at top. Effective 9/29/03.</p>	<p>Present</p> <p>Present</p> <p>Present</p>
May 2004	Double Hung	<p>March 1, 2004: Pebble exterior / white interior GBGs available.</p>	<p>Present</p>
October 2005	Double Hung	<p>October 10, 2005: Sash weather strip V1232 was removed and replaced with frame weather strip as a running change.</p>	<p>October 2005</p>
January 2006	Double Hung	<p>January 2006: Integrity Double Hung discontinued.</p>	<p>January 2006</p>

When ordering replacement hardware specify:

1. Type of unit;
2. Part number;
3. Description.

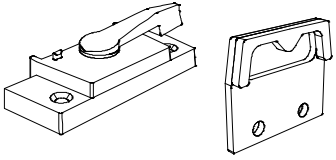
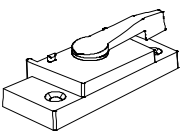

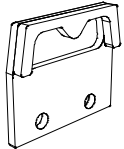
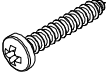
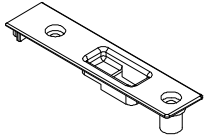
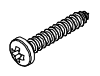
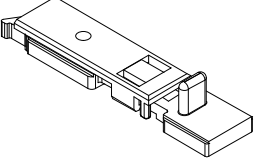

ILLUSTRATION <i>NOT TO SCALE</i>	DESCRIPTION	LENGTH/COLOR	PART NO.
	<p>Sash Lock and Keeper, Complete Includes: 1 - Sash Lock 2 - #6 x 1 1/4" Phillips flathead screws 1 - Keeper</p>	<p>AF WH</p>	<p>11869302 11869718</p>
	<p>Sash Lock includes fasteners: 2 - #6 x 1 1/4" Phillips flathead wood screws AF - 11806001 WH - 11806002</p>	<p>AF WH</p>	<p>10817035 10817027</p>
	<p>Sash Lock Screws, Package Includes: 50 - #6 x 1 1/4" Phillips flathead screws</p>	<p>AF WH</p>	<p>11869305 11869727</p>
	<p>Sash Keeper includes fasteners: 2 - #8 x 1" Phillips pan head screws AF - 11800814 WH - 11800820</p>	<p>AF WH</p>	<p>10817036 10817029</p>
	<p>Sash Keeper Screws, Package Includes: 50 - #8 x 1" Phillips pan head screws</p>	<p>AF WH</p>	<p>11869306 11869728</p>
	<p>Tilt Latch Cover includes fasteners: 2 - #8 x 1" Phillips pan head screws AF - 11800814 WH - 11800820</p>	<p>AF WH</p>	<p>11869713 11869717</p>
	<p>Tilt Latch Cover Screws, Package Includes: 50 - #8 x 1" Phillips pan head screws</p>	<p>AF WH</p>	<p>11869308 11869730</p>
 <p>Note: Right hand shown</p>	<p>Tilt Latch includes fasteners: 2 - #8x3/4" Phillips truss head screws AF - 11800833 WH - 11800828</p>	<p>LH AF RH AF LH WH RH WH</p>	<p>11869712 11869710 11869716 11869715</p>
	<p>Tilt Latch Screws, Package Includes: 50 - #8 x 3/4" Phillips truss head screws</p>	<p>AF WH</p>	<p>11869307 11869729</p>

ILLUSTRATION NOT TO SCALE	DESCRIPTION	LENGTH/COLOR	PART NO.
	<p>Clutch</p> <p><i>NOTE: Non-handed</i></p>		10661009
	<p>Sash Pivot Pin</p> <p>includes fasteners: 1 – Pivot Pin 2 – #7 x 5/8" Phillips self tapping flat head screw 11800758</p> <p><i>NOTE: Pivot pins are non-handed</i></p>		10660999
	<p>Sash Pivot Pin</p>	<p>No longer available Replace with 10660999</p>	
	<p>Hanger Clip</p>		10661000
	<p>Stationary Bracket</p>		11040359

ILLUSTRATION <i>NOT TO SCALE</i>	DESCRIPTION	LENGTH/COLOR	PART NO.
	Frame to Sash Seal, Picture and Transom	150' (46 meters) BK	10501118

When ordering replacement Integrity Double Hung weather strip specify:

1. Description;
2. Profile number;
3. Part number;
4. Quantity.



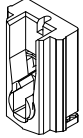
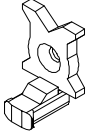
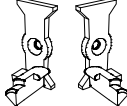
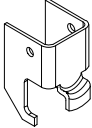
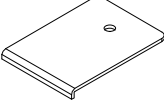
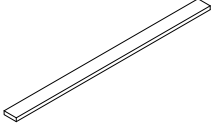



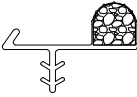
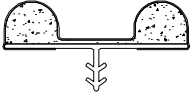
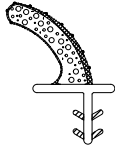
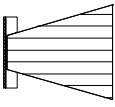

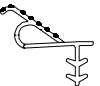

ILLUSTRATION <i>NOT TO SCALE</i>	DESCRIPTION	LENGTH/COLOR	PART NO.
	Sash Pivot Pin Pad 5/16" x 11/16" <i>NOTE: Adhesive backed</i>	GY	15607568
	Sill/Jamb Plug 5/8" x 13/16" x 13/16"	WH	11040354
	Sill / Jamb Plug Usage: 4/95–11/96	No longer available Replaced with 11040354	
	Sash Stops V820 Each Package of 10 144" (3658) lineal	BG	11860107 11869297 11860110
	Head Jamb Parting Stop V248 CN22 CN26 CN30 CN34 CN36 CN38 CN42 Lineal	BG 19 7/16" (494) 23 7/16" (595) 27 7/16" (697) 31 7/16" (799) 33 7/16" (849) 35 7/16" (900) 39 7/16" (1002) 84" (2134)	17003122 17003126 17003130 17003134 17003136 17003138 17003142 17003184
	Double Hung Head Jamb Weather Strip V192 Usage: 4/95–11/96	No longer available Replaced with V248	
	Top Jamb Weather Strip V169 CN36 CN40 CN48 CN52 CN56 CN60 CN64 CN68 CN72 Lineal	BG 17" (432) 19" (483) 23" (584) 25" (635) 27" (686) 29" (737) 31" (787) 27" (686) 35" (889) 144" (3658)	17002036 17002040 17002048 17002052 17002056 17002060 17002064 17002056 17002072 17002999

ILLUSTRATION NOT TO SCALE	DESCRIPTION	LENGTH	PART NO.																														
	Double Hung Head Jamb Weather Strip V144 Usage: 4/95-10/02	No longer available Replaced with V169																															
	Bottom Jamb Weather Strip V1194	BG	<table border="0"> <tr><td>CN36</td><td>17" (432)</td><td>17003536</td></tr> <tr><td>CN40</td><td>19" (483)</td><td>17003540</td></tr> <tr><td>CN48</td><td>23" (584)</td><td>17003548</td></tr> <tr><td>CN52</td><td>25" (635)</td><td>17003552</td></tr> <tr><td>CN56</td><td>27" (686)</td><td>17003556</td></tr> <tr><td>CN60</td><td>29" (737)</td><td>17003560</td></tr> <tr><td>CN64</td><td>31" (787)</td><td>17003564</td></tr> <tr><td>*CN68C</td><td>39" (889)</td><td>17003568</td></tr> <tr><td>CN72</td><td>35" (889)</td><td>17003572</td></tr> <tr><td></td><td>144" (3658)</td><td>17003599</td></tr> </table>	CN36	17" (432)	17003536	CN40	19" (483)	17003540	CN48	23" (584)	17003548	CN52	25" (635)	17003552	CN56	27" (686)	17003556	CN60	29" (737)	17003560	CN64	31" (787)	17003564	*CN68C	39" (889)	17003568	CN72	35" (889)	17003572		144" (3658)	17003599
CN36	17" (432)	17003536																															
CN40	19" (483)	17003540																															
CN48	23" (584)	17003548																															
CN52	25" (635)	17003552																															
CN56	27" (686)	17003556																															
CN60	29" (737)	17003560																															
CN64	31" (787)	17003564																															
*CN68C	39" (889)	17003568																															
CN72	35" (889)	17003572																															
	144" (3658)	17003599																															
	Frame Weather Strip, Pile V1494	BG	<table border="0"> <tr><td>CN36</td><td>18 1/8" (460)</td><td>17009036</td></tr> <tr><td>CN40</td><td>20 1/8" (511)</td><td>17009040</td></tr> <tr><td>CN48</td><td>24 1/8" (613)</td><td>17009048</td></tr> <tr><td>CN52</td><td>26 1/8" (664)</td><td>17009052</td></tr> <tr><td>CN56</td><td>28 1/8" (714)</td><td>17009056</td></tr> <tr><td>CN60</td><td>30 1/8" (765)</td><td>17009060</td></tr> <tr><td>CN64</td><td>32 1/8" (816)</td><td>17009064</td></tr> <tr><td>*CN68C</td><td>40 1/8" (1019)</td><td>17009068</td></tr> <tr><td>72</td><td>36 1/8" (918)</td><td>17009072</td></tr> <tr><td>Lineal</td><td>120" (3048)</td><td>17009098</td></tr> </table>	CN36	18 1/8" (460)	17009036	CN40	20 1/8" (511)	17009040	CN48	24 1/8" (613)	17009048	CN52	26 1/8" (664)	17009052	CN56	28 1/8" (714)	17009056	CN60	30 1/8" (765)	17009060	CN64	32 1/8" (816)	17009064	*CN68C	40 1/8" (1019)	17009068	72	36 1/8" (918)	17009072	Lineal	120" (3048)	17009098
CN36	18 1/8" (460)	17009036																															
CN40	20 1/8" (511)	17009040																															
CN48	24 1/8" (613)	17009048																															
CN52	26 1/8" (664)	17009052																															
CN56	28 1/8" (714)	17009056																															
CN60	30 1/8" (765)	17009060																															
CN64	32 1/8" (816)	17009064																															
*CN68C	40 1/8" (1019)	17009068																															
72	36 1/8" (918)	17009072																															
Lineal	120" (3048)	17009098																															
	Sill Weather Strip V1165	BG	<table border="0"> <tr><td>CN22</td><td>20 3/8" (518)</td><td>17003622</td></tr> <tr><td>CN26</td><td>24 3/8" (619)</td><td>17003626</td></tr> <tr><td>CN30</td><td>28 3/8" (721)</td><td>17003630</td></tr> <tr><td>CN34</td><td>32 3/8" (822)</td><td>17003634</td></tr> <tr><td>CN36</td><td>34 3/8" (873)</td><td>17003636</td></tr> <tr><td>CN38</td><td>36 3/8" (924)</td><td>17003638</td></tr> <tr><td>CN42</td><td>40 3/8" (1026)</td><td>17003642</td></tr> <tr><td></td><td>150" (3810)</td><td>17003699</td></tr> </table>	CN22	20 3/8" (518)	17003622	CN26	24 3/8" (619)	17003626	CN30	28 3/8" (721)	17003630	CN34	32 3/8" (822)	17003634	CN36	34 3/8" (873)	17003636	CN38	36 3/8" (924)	17003638	CN42	40 3/8" (1026)	17003642		150" (3810)	17003699						
CN22	20 3/8" (518)	17003622																															
CN26	24 3/8" (619)	17003626																															
CN30	28 3/8" (721)	17003630																															
CN34	32 3/8" (822)	17003634																															
CN36	34 3/8" (873)	17003636																															
CN38	36 3/8" (924)	17003638																															
CN42	40 3/8" (1026)	17003642																															
	150" (3810)	17003699																															
	Sill Weather Strip V191 Usage: 4/95-9/03	No Longer Available Replaced with V1165																															

* Cottage style sash

ILLUSTRATION NOT TO SCALE	DESCRIPTION	LENGTH	PART NO.		
	Bottom Sash Foam Weather Strip V1232	BG CN36 17 3/16" (437) CN40 19 3/16" (487) CN48 23 3/16" (589) CN52 25 3/16" (640) CN56 27 3/16" (691) CN60 29 3/16" (741) CN64 31 3/16" (792) CN72 35 3/16" (894) *CN68BC 39 3/16" (995) Lineal 144" (3658)	17003436 17003440 17003448 17003452 17003456 17003460 17003464 17003472 17003468 17003499		
		Check Rail Weather Strip V150	BG CN22 19 1/8" (487) CN26 23 1/8" (588) CN30 27 1/8" (690) CN34 31 1/8" (791) CN36 33 1/8" (842) CN38 35 1/8" (893) CN42 39 1/8" (995) Lineal 150" (3810)	17001822 17001826 17001830 17001834 17001836 17001838 17001842 17001899	
			Head Jamb Weather Strip V140 For double hung picture and transom units	BG CN22 19 21/64" (491) CN26 23 21/64" (593) CN30 27 21/64" (694) CN34 31 21/64" (796) CN36 33 21/64" (847) CN38 35 21/64" (897) CN42 39 21/64" (999) CN50 47 21/64" (1202) CN54 51 21/64" (1304) CN62 59 21/64" (1507)	17002322 17002326 17002330 17002334 17002336 17002338 17002342 17002350 17002354 17002362
			Jamb Weather Strip V140 For double hung picture and transom units	BG CN16 12 5/64" (307) CN48 44 5/64" (1120) CN52 48 5/64" (1221) CN56 52 5/64" (1323) CN60 56 5/64" (1424) CN64 60 5/64" (1526) *CN68C 64 5/64" (1628)	17002316 17002348 17002352 17002356 17002360 17002364 17002368

* Cottage style sash

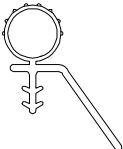
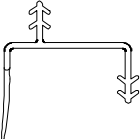
ILLUSTRATION NOT TO SCALE	DESCRIPTION	LENGTH	PART NO.
	Sill Interior Stop Weather Strip V141 BG For double hung picture and transom units		
	CN22	19 21/64" (491)	17002422
	CN26	23 21/64" (593)	17002426
	CN30	27 21/64" (694)	17002430
	CN34	31 21/64" (796)	17002434
	CN36	33 21/64" (847)	17002436
	CN38	35 21/64" (897)	17002438
	CN42	39 21/64" (999)	17002442
	CN50	47 21/64" (1202)	17002450
	CN54	51 21/64" (1304)	17002454
	CN62	59 21/64" (1507)	17002462
Lineal	144" (3658)	17002499	
 <p data-bbox="164 989 529 1129"><i>NOTE: Field service items (for replacement only) on units produced before November 18, 1996. Replaces V144 and V161</i></p>	Jamb Hardware Weather Strip V167	BG	
CN36	34" (864)	17002836	
CN40	38" (965)	17002840	
CN48	46" (1168)	17002848	
CN52	50" (1270)	17002852	
CN56	54" (1372)	17002856	
CN60	58" (1473)	17002860	
CN64	62" (1575)	17002864	
CN72	70" (1778)	17002872	
Lineal	144" (3658)	17002899	
 <p data-bbox="164 1518 561 1659"><i>NOTE: For complete replacement of weather strip on units produced between November 18, 1996 and October 24, 2005.</i></p>	Field Service Weather Strip Kit Usage: 12/2011 to present <i>Includes:</i> 4 - V169 Top jamb weather strip (a) 2 - Checkrail pads (b) 2 - V1494 Pile weather strip(2 inch piece)(c) 2 - Sill Jamb Plug (d) 1 - Instruction 19972110		
CN36	34" (864)	11860900	
CN40	38" (965)	11860901	
CN48	46" (1168)	11860902	
CN52	50" (1270)	11860903	
CN56	54" (1372)	11860904	
CN60	58" (1473)	11860905	
CN64	62" (1575)	11860906	
Cottage CN68		11860907	
CN72	70" (1778)	11860908	

ILLUSTRATION NOT TO SCALE	DESCRIPTION	LENGTH	PART NO.
 <p>Field Service Weather Strip Kit Usage: Kit used prior to 12/2011</p> <p><i>Includes:</i> 2 - V169 Top jamb weather strip (a) 2 - V1194 Bottom jamb weather strip (b) 2 - V1494 Pile weather strip (c) 2 - Checkrail pads (d) 1 - Instruction 19972110</p> <p>NOTE: For complete replacement of weather strip on units produced between November 18, 1996 and October 24, 2005.</p>	<p>CN36 CN40 CN48 CN52 CN56 CN60 CN64 Cottage CN68 CN72</p>	<p>34" (864) 38" (965) 46" (1168) 50" (1270) 54" (1372) 58" (1473) 62" (1575) 70" (1778)</p>	<p>NA replace with current weather strip kit</p>
	<p>Sill Filler* A441</p> <p>CN22 CN26 CN30 CN34 CN36 CN38 CN42 CN50 CN54 CN62</p> <p>CN22 CN26 CN30 CN34 CN36 CN38 CN42 CN50 CN54 CN62</p> <p>CN22 CN26 CN30 CN34 CN36 CN38 CN42 CN50 CN54 CN62</p>	<p>SW</p> <p>19 3/16" (487) 23 3/16" (589) 27 3/16" (691) 31 3/16" (792) 33 3/16" (843) 35 3/16" (894) 39 3/16" (995) 47 3/16" (1199) 51 3/16" (1300) 59 3/16" (1503)</p> <p>PB</p> <p>19 3/16" (487) 23 3/16" (589) 27 3/16" (691) 31 3/16" (792) 33 3/16" (843) 35 3/16" (894) 39 3/16" (995) 47 3/16" (1199) 51 3/16" (1300) 59 3/16" (1503)</p> <p>AR</p> <p>19 3/16" (487) 23 3/16" (589) 27 3/16" (691) 31 3/16" (792) 33 3/16" (843) 35 3/16" (894) 39 3/16" (995) 47 3/16" (1199) 51 3/16" (1300) 59 3/16" (1503)</p>	<p>19611422 19611426 19611430 19611434 19611436 19611438 19611442 19611450 19611454 19611462</p> <p>18611522 18611526 18611530 18611534 18611536 18611538 18611542 18611550 18611554 18611562</p> <p>18611422 18611426 18611430 18611434 18611436 18611438 18611442 18611450 18611454 18611462</p>

TO ORDER REPLACEMENT WOOD PARTS

When ordering replacement wood parts specify:

1. Profile number;
2. Part number;
3. Length;
4. Handing (if applicable);
5. Bare wood or white interior.

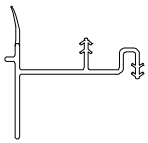
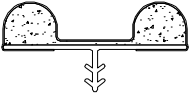
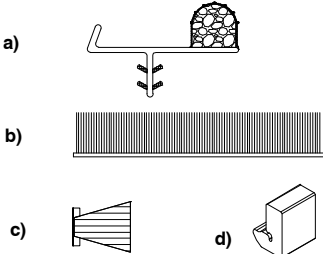
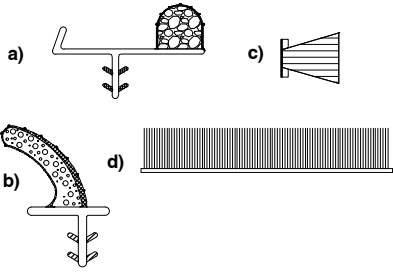
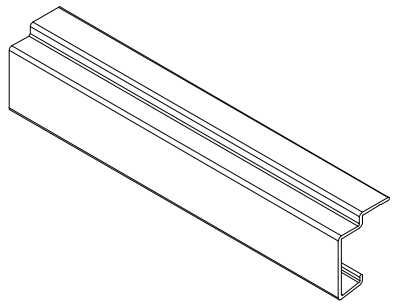
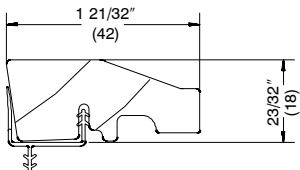
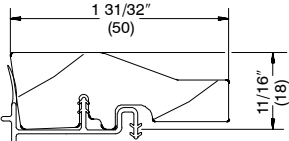
ILLUSTRATION <i>NOT TO SCALE</i>	DESCRIPTION	LENGTH	BARE WOOD PART NO.	WHITE INTERIOR PART NO.
 <p>W7430 – Head Jamb and Jamb Stop, Picture and Transom Units V140 – Head Jamb Weather Strip included</p>	<p>Interior Stop– Head Jamb W7430</p> <p>CN22 CN26 CN30 CN34 CN36 CN38 CN42 CN50 CN54 CN62</p>	<p>19 3/8" (492) 23 3/8" (594) 27 3/8" (695) 31 3/8" (797) 33 3/8" (848) 35 3/8" (898) 39 3/8" (1000) 47 3/8" (1203) 51 3/8" (1305) 59 3/8" (1508)</p>	<p>31500422 31500426 31500430 31500434 31500436 31500438 31500442 31500450 31500454 31500462</p>	<p>39200422 39200426 39200430 39200434 39200436 39200438 39200442 39200450 39200454 39200462</p>
	<p>Interior Stop– Jamb W7430</p> <p>CN16 CN48 CN52 CN56 CN60 CN64 Cottage CN68</p>	<p>12 39/64" (320) 44 39/64" (1133) 48 39/64" (1235) 52 39/64" (1836) 56 39/64" (1438) 60 39/64" (1539) 64 39/64" (1641)</p>	<p>31500516 31500548 31500552 31500556 31500560 31500564 31500568</p>	<p>39200516 39200548 39200552 39200556 39200560 39200564 39200568</p>
 <p>W7429 – Sill Stop Picture and Transom Unit V141 – Sill Weather Strip included</p>	<p>Interior Stop–Sill W7429</p> <p>CN22 CN26 CN30 CN34 CN36 CN38 CN42 CN50 CN54 CN62</p>	<p>19 3/8" (492) 23 3/8" (594) 27 3/8" (695) 31 3/8" (797) 33 3/8" (848) 35 3/8" (898) 39 3/8" (1000) 47 3/8" (1203) 51 3/8" (1305) 59 3/8" (1508)</p>	<p>31500322 31500326 31500330 31500334 31500336 31500338 31500342 31500350 31500354 31500362</p>	<p>39200322 39200326 39200330 39200334 39200336 39200338 39200342 39200350 39200354 39200362</p>

ATTENTION ON RETROFIT UNITS ORDERED BEFORE 1/20/03: If the installer is retrofitting units ordered before 1/20/03 with the HP Sill Liner Kit, they must replace the tilt latches. This will allow the unit to achieve the certified structural performance rating.

ILLUSTRATION NOT TO SCALE	DESCRIPTION	LENGTH	BARE WOOD PART NO.	WHITE INTERIOR PART NO.
	<p>IDH HP Field Applied Sill Liner Kit – Picture/Transom</p> <p><i>Includes:</i> 1–W8586 HP Sill Liner (Adhesive tape applied) 4–#8 x 1 1/2" Phillips panhead screws–11865161 1–Installation Instruction–19970048</p>			
	<p>IDH HP Field Applied Sill Liner Kit – Operator</p> <p><i>Includes:</i> 1–W8088 HP Sill Liner (Adhesive tape applied) 4–#8 x 1 1/2" Phillips panhead screws–11865161 1–Installation Instruction–19970048</p>			
	<p>CN22</p> <p>CN26</p> <p>CN30</p> <p>CN34</p> <p>CN36</p> <p>CN38</p> <p>CN42</p> <p>CN50</p> <p>CN54</p> <p>CN62</p>	<p>20 3/32" (511)</p> <p>24 3/32" (612)</p> <p>28 3/32" (714)</p> <p>32 3/32" (815)</p> <p>34 3/32" (866)</p> <p>36 3/32" (917)</p> <p>40 3/32" (1019)</p> <p>48 3/32" (1222)</p> <p>52 3/32" (1327)</p> <p>60 3/32" (1527)</p>	<p>11886022</p> <p>11886026</p> <p>11886030</p> <p>11886034</p> <p>11886036</p> <p>11886038</p> <p>11886042</p> <p>11886050</p> <p>11886054</p> <p>11886062</p>	<p>39256022</p> <p>39256026</p> <p>39256030</p> <p>39256034</p> <p>39256036</p> <p>39256038</p> <p>39256042</p> <p>39256050</p> <p>39256054</p> <p>39256062</p>
	<p>CN22</p> <p>CN26</p> <p>CN30</p> <p>CN34</p> <p>CN36</p> <p>CN38</p> <p>CN42</p>	<p>20 3/32" (511)</p> <p>24 3/32" (612)</p> <p>28 3/32" (714)</p> <p>32 3/32" (815)</p> <p>34 3/32" (866)</p> <p>36 3/32" (917)</p> <p>40 3/32" (1019)</p>	<p>11887022</p> <p>11887026</p> <p>11887030</p> <p>11887034</p> <p>11887036</p> <p>11887038</p> <p>11887042</p>	<p>39257022</p> <p>39257026</p> <p>39257030</p> <p>39257034</p> <p>39257036</p> <p>39257038</p> <p>39257042</p>

BALANCE TUBES

When ordering replacement parts specify:

1. Part number;
2. Quantity;
3. Top or bottom sash.

NOTE: Part numbers listed are for one balance tube.

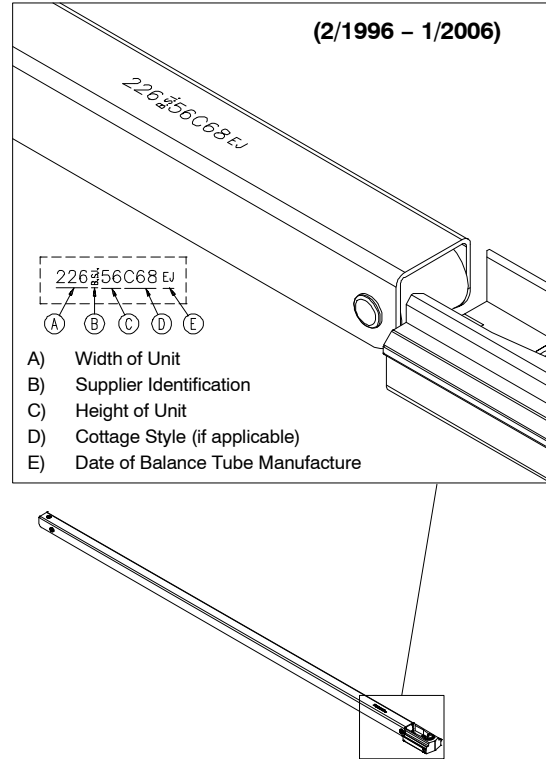
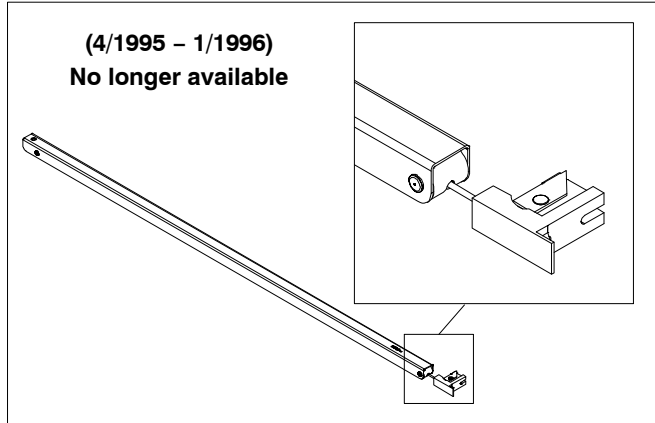

Top Sash (Mill Finish)								
Call Number Height	22-26CN Width		30-34CN Width		36-38CN Width		42CN Width	
	No. Stamped on Tube	Integrity Part No.	No. Stamped on Tube	Integrity Part No.	No. Stamped on Tube	Integrity Part No.	No. Stamped on Tube	Integrity Part No.
36	226-36	10661036	304-36	10662036	368-36	10663036	42-36	10664036
40	226-40	10661040	304-40	10662040	368-40	10663040	42-40	10664040
48	226-48	10661048	304-48	10662048	368-48	10663048	42-48	10664048
52	226-52	10661052	304-52	10662052	368-52	10663052	42-52	10664052
56C68	226-56C68	10661056	304-56	10662056	368-56	10663056	42-56C68	10664056
60	226-60	10661060	304-60	10662060	368-60	10663060	42-60	10664060
64	226-64	10661064	304-64	10662064	368-64	10663064	42-64	10664064
72	226-72	10661072	304-72	10662072	368-72	10663072	42-72	10664072
Bottom Sash (Beige Finish)								
Call Number Height	22-26CN Width		30-34CN Width		36-38CN Width		42CN Width	
	No. Stamped on Tube	Integrity Part No.	No. Stamped on Tube	Integrity Part No.	No. Stamped on Tube	Integrity Part No.	No. Stamped on Tube	Integrity Part No.
36	226-36	10661136	304-36	10662136	368-36	10663136	42-36	10664136
40	226-40	10661140	304-40	10662140	368-40	10663140	42-40	10664140
48	226-48	10661148	304-48	10662148	368-48	10663148	42-48	10664148
52	226-52	10661152	304-52	10662152	368-52	10663152	42-52	10664152
56	226-56	10661156	304-56	10662156	368-56	10663156	42-56	10664156
60	226-60	10661160	304-60	10662160	368-60	10663160	42-60	10664160
64	226-64	10661164	304-64	10662164	368-64	10663164	42-64	10664164
72C68	226-72C68	10661172	304-72	10662172	368-72	10663172	42-72	10664172

ORDERING DOUBLE HUNG REPLACEMENT SASH

When ordering replacement sash specify:

1. Specify top, bottom or pair of sash;
2. Size (using chart below):
3. Sash exterior color
4. Hardware color – White or Almond Frost;
5. Glazing;
6. Bare wood or white interior.

Sash Sizes for Double Hung (IDH) manufactured 1995 to January 2006			
Daylight Opening to OM of Sash			
Daylight Width + 3 1/2" = OM Width of Sash			
Daylight Height + 3 1/2" = OM Height of Sash			
NOTE: Sash is not reglazable			
Operator Sash			
Width		Height	
Size	OM Width	Size	OM Height
CN22	19 3/16" (487)	CN 36	17 3/16" (437)
CN26	23 3/16" (589)	CN 40	19 3/16" (487)
CN30	27 3/16" (691)	CN 48	23 3/16" (589)
CN34	31 3/16" (792)	CN 52	25 3/16" (640)
CN36	33 3/16" (843)	CN 56	27 3/16" (691)
CN38	35 3/16" (894)	CN 60	29 3/16" (741)
CN42	39 3/16" (995)	CN 64	31 3/16" (792)
CN50	47 3/16" (1199)	CN 68 (top)	27 3/16" (691)
CN54	51 3/16" (1300)	CN 68 (btm)	39 3/16" (995)
CN62	59 3/16" (1503)	CN 72	35 3/16" (894)
CN54	51 3/16" (1300)	CN 68 (btm)	39 3/16" (995)
Picture/Transom Sash			
Width		Height	
Size	OM Width	Size	OM Height
CN22	18 15/16" (481)	CN16	12 15/16" (329)
CN26	22 15/16" (583)	CN24	20 15/16" (532)
CN30	26 15/16" (684)	CN36	31 15/16" (837)
CN32	28 15/16" (735)	CN40	36 15/16" (938)
CN34	30 15/16" (786)	CN44	40 15/16" (1040)
CN36	32 15/16" (837)	CN48	44 15/16" (1141)
CN38	34 15/16" (888)	CN52	48 15/16" (1243)
CN42	38 15/16" (988)	CN56	52 15/16" (1345)
CN50	46 15/16" (1192)	CN60	56 15/16" (1446)
CN54	50 15/16" (1294)	CN64	60 15/16" (1548)
CN62	58 15/16" (1497)	CN68	64 15/16" (1649)
		CN72	68 15/16" (1751)
		CN76	72 15/16" (1853)

NOTE: Double Hung replacement sash is supplied with weather strip and hardware. CN 68 height pertains to cottage style sash. Daylight opening is the measurement of visible glass. Double Hung picture replacement sash includes attached sill filler.

Top Sash Interior View



Bottom Sash Interior View

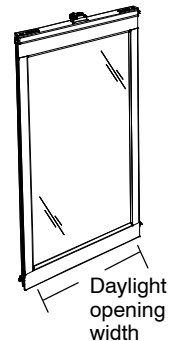

ORDERING REPLACEMENT GRILLES

When ordering replacement grilles specify:

1. Call number (using chart below);
2. Bare wood or white interior.

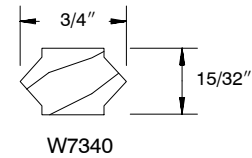

W7340
GRILLE END PROFILE

DOUBLE HUNG OPERATOR AND STATIONARY							
WIDTH				HEIGHT			
CN	SASH OM	DLO	GRILLE CUT	CN	SASH OM	DLO	GRILLE CUT
CN22	18 15/16" (481)	15 11/16" (398)	2W	CN36	16 15/16" (430)	13 11/16" (348)	2H
CN26	22 15/16" (583)	19 11/16" (500)	3W	CN40	18 15/16" (481)	15 11/16" (398)	2H
CN30	26 15/16" (684)	23 11/16" (602)	3W	CN44	20 15/16" (532)	17 11/16" (449)	2H
CN32	28 15/16" (735)	25 11/16" (652)	3W	CN48	22 15/16" (583)	19 11/16" (500)	2H
CN34	30 15/16" (786)	27 11/16" (703)	3W	CN52	24 15/16" (633)	21 11/16" (551)	2H
CN36	32 15/16" (837)	29 11/16" (754)	3W	CN56	26 15/16" (684)	23 11/16" (602)	2H
CN38	34 15/16" (888)	31 11/16" (805)	4W	CN60	28 15/16" (735)	25 11/16" (652)	2H
CN42	38 15/16" (988)	35 11/16" (906)	4W	CN64	30 15/16" (786)	27 11/16" (703)	2H
				*CN68C (TOP)	26 15/16" (684)	23 11/16" (602)	2H
				*CN68C (BTM)	38 15/16" (989)	35 11/16" (906)	3H
				CN72	34 15/16" (887)	31 11/16" (805)	3H

*Cottage style sash

DOUBLE HUNG PICTURE AND TRANSOM							
WIDTH				HEIGHT			
CN	SASH OM	DLO	GRILLE CUT	CN	SASH OM	DLO	GRILLE CUT
CN22	18 15/16" (481)	15 11/16" (398)	2W	CN16	12 15/16" (481)	9 11/16" (246)	1H
CN26	22 15/16" (583)	19 11/16" (500)	3W	CN48	44 15/16" (1141)	41 11/16" (1059)	4H
CN30	26 15/16" (684)	23 11/16" (602)	3W	CN52	48 15/16" (1243)	45 11/16" (1160)	4H
CN34	30 15/16" (786)	27 11/16" (703)	3W	CN56	52 15/16" (1345)	49 11/16" (1262)	4H
CN36	32 15/16" (837)	29 11/16" (754)	3W	CN60	56 15/16" (1446)	53 11/16" (1364)	4H
CN38	34 15/16" (888)	31 11/16" (805)	4W	CN64	60 15/16" (1548)	57 11/16" (1465)	4H
CN42	38 15/16" (988)	35 11/16" (906)	4W	CN68	64 15/16" (1649)	61 11/16" (1567)	4H
CN50	46 15/16" (1192)	43 11/16" (1110)	5W				
CN54	50 15/16" (1294)	47 11/16" (1211)	5W				
CN62	58 15/16" (1497)	55 11/16" (1414)	6W				

ORDERING REPLACEMENT SCREENS FOR INTEGRITY DOUBLE HUNG

Screens are standard with a white or pebble gray aluminum surround and charcoal colored fiberglass 18x16 screen mesh. Determine the outside measurement of the existing screen. Find the sizes that correspond to the width and height indicated on the following chart.

When ordering replacement screen specify:

1. Size; – if there is no existing screen from which to obtain the OM of the screen, determine the size of the screen by using the conversion chart below. The daylight opening is the measurement of the visible glass.
2. Color
3. Specify cottage or equal sash when ordering CN68 height.

Screen Sizes for Double Hung (IDH) manufactured 1995 to January 2006			
Daylight Opening to OM of Screen			
Daylight Width + 4 9/16" = OM Width of Screen			
Daylight Height x 2 + 7 19/32" = OM Height of Screen			
NOTE: Screen feature plunger type mounting system.			
Width		Height	
Size	OM Width	Size	OM Height
CN 22	20 1/4" (514)	CN 36	34 31/32" (888)
CN 26	24 1/4" (616)	CN 40	38 31/32" (990)
CN 30	28 1/4" (718)	CN 48	46 31/32" (1193)
CN 34	32 1/4" (819)	CN 52	50 31/32" (1295)
CN 36	34 1/4" (870)	CN 56	54 31/32" (1396)
CN 38	36 1/4" (921)	CN 60	58 31/32" (1498)
CN 42	40 1/4" (1022)	CN 64	62 31/32" (1599)
		CN 68	66 31/32" (1701)
		CN 72	70 31/32" (1803)

NOTE: Measure top and bottom sash separately when calculating screen OM height. CN36 and CN40 screens do not feature cross bars.

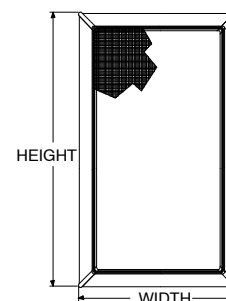

NOTE: OM of screen includes corner keys.

ILLUSTRATION <i>NOT TO SCALE</i>	DESCRIPTION	OPER./COLOR	PART NO.
	Plunger and Spring Assembly–M060 <i>Includes:</i> 1 – Plunger bolt 1 – Plunger bolt cap 1 – Plunger bolt spring	Clear Cap Off White Bolt	11900896

Tools needed: Stiff putty knife or pry bar
90° Allen wrench (or similarly fashioned tool)
Rubber mallet

Parts needed: Stationary sill bracket
Frame to sash seal
Interior sill stop (W7429)
Interior head jamb and jamb stop (W7430)
Sill interior stop weather strip (V141)

Removing Stationary Sash

1. Begin by removing the wood jamb interior stops with a stiff putty knife as shown in illustration 6. Next remove the vinyl jamb interior stop weather strip.

NOTE: Exercise care in removing the vinyl stops from the frame kerf as they will be reused.

2. Remove the wood head jamb interior stops and vinyl interior stop weather strip in the same fashion as in step 1. See illustration 7.

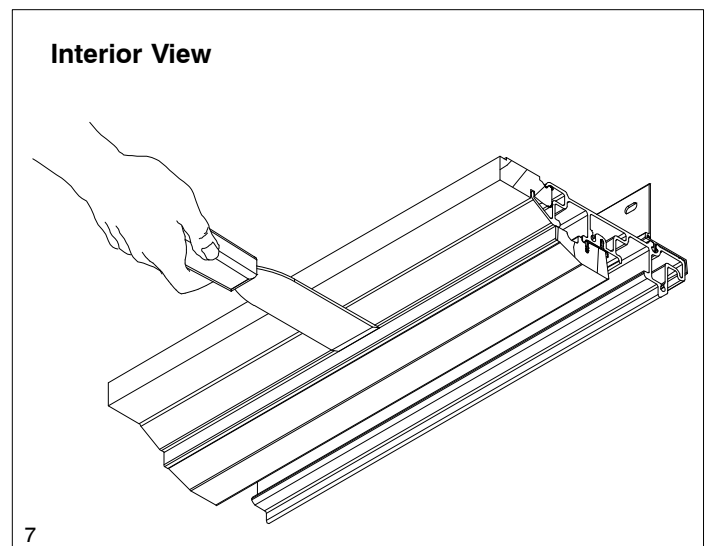
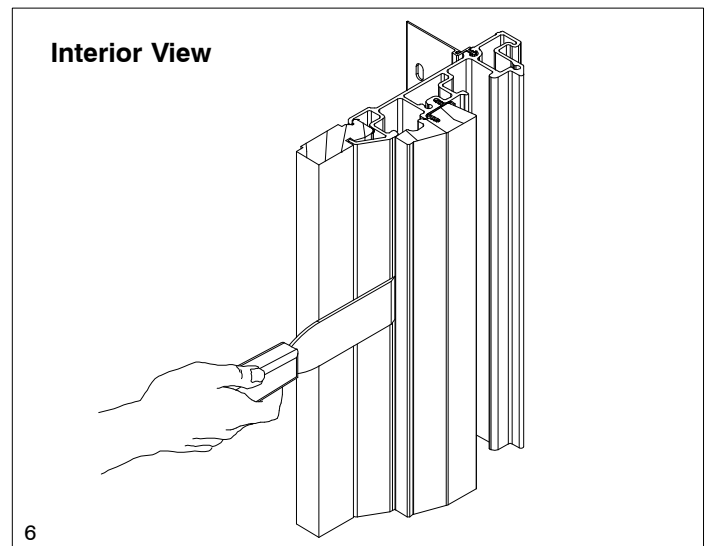

Removing Stationary Sash (Continued)

- Using the 90° Allen wrench (or similarly fashioned tool) hook the wood sill interior stop in the balance tube cavity as shown in illustration 8. Remove the vinyl sill stop weather strip.

NOTE: Interior wood sill stop may be removed with a stiff putty knife but use caution as Ultrex sill may crack or break.

- Bend the sill stationary bracket(s) up to allow for sash removal. See illustration 9.
- Carefully pull the top of the sash into the interior with a stiff putty knife or pry bar. Grasp the sash and lift out of the frame. See illustration 10.
- Once the stationary sash is out, bend the sill stationary brackets back to their original position before replacing sash.

NOTE: Before replacing the sash, make sure that the sash to frame adhesive foam found along the Ultrex jamb and head jamb is intact to ensure a proper seal.

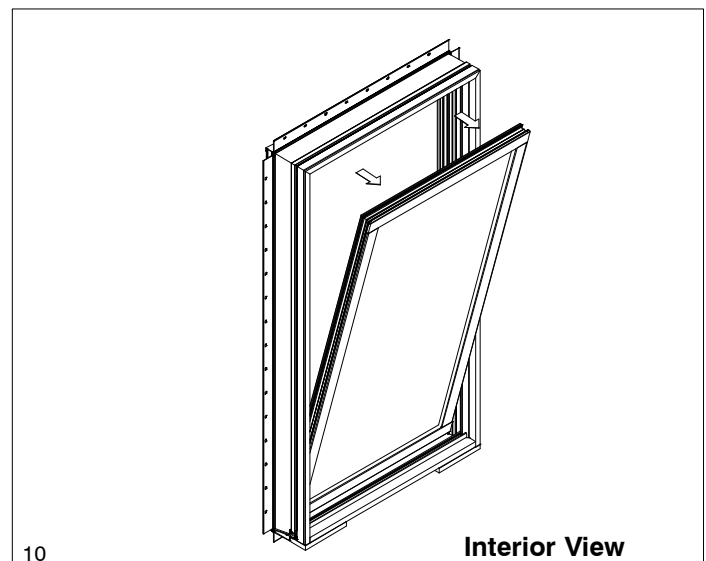
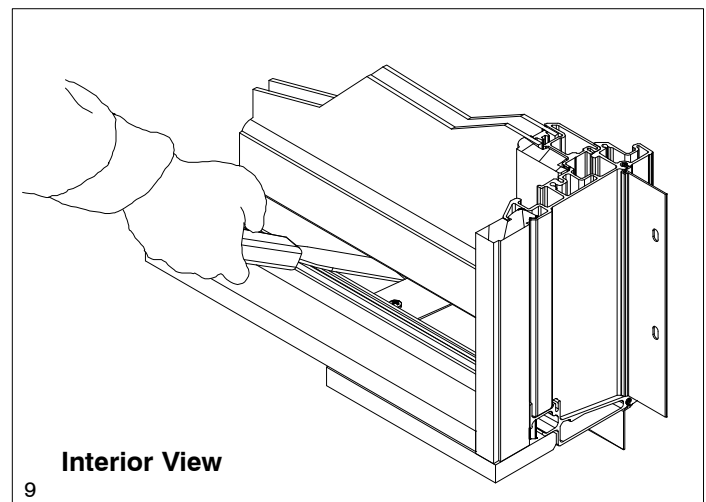
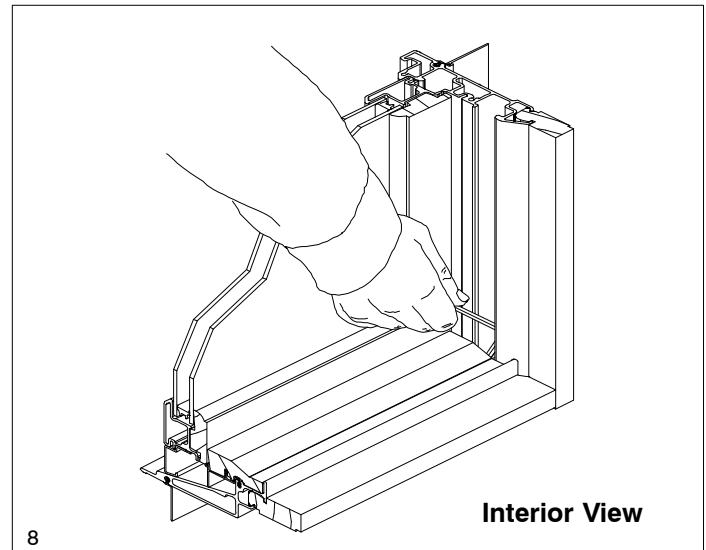

Replacing Stationary Sash

1. Grasp the sash and set the bottom into the frame first. Be sure that the stationary sill bracket engages with the sill filler. Tilt the top of the sash into the frame. See illustration 11.

NOTE: *Sill filler is supplied and attached to replacement sash.*

2. Replace the bottom and top vinyl stop weather strip by placing the connecting barb into the frame kerf. Replace the wood top stop and the bottom stop. If necessary, tap into place with rubber mallet. Replace the jamb vinyl stop weather strip and wood jamb stop in the same manner as the head jamb and sill stop.

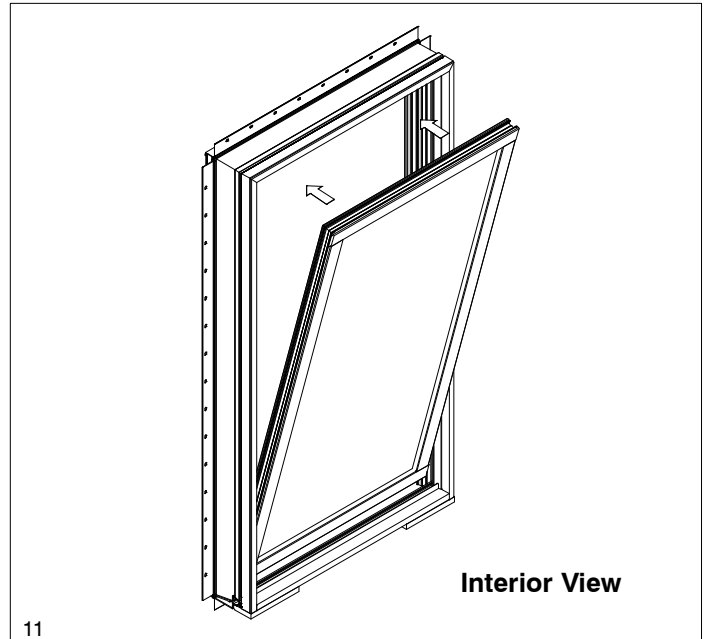

Tools needed: Standard flat screwdriver
 Tape measure
 Pencil
 Balance tube channel spreader (see note below)

Parts needed: Balance tube(s)

1. Remove sash (see Index, Tilting or Removing Double Hung Sash).
2. Release clutches by rotating cam to the released position with a standard screwdriver. Carefully raise to the bottom of the balance tube. See illustration 12.
3. Remove balance tube foam block from head jamb channel. If replacing the bottom balance tube, slide the sash stop down the balance tube and squeeze to remove. See illustration 13.
4. Insert balance tube channel spreader below clutch assembly and turn to spread Ultrac channel. See illustration 14.

NOTE: *It is necessary to spread the Ultrac channel in order to remove the balance tube clutch assembly. The balance tube channel spreader can be fabricated from a 1/2" x 3/4" x 6" piece of oak or hard wood. Round off the corners to 11/16". See illustration 14. The handle of a screwdriver may also be a suitable substitute provided that its diameter is no larger than 5/8". Insert handle below clutch assembly and pry to the interior.*

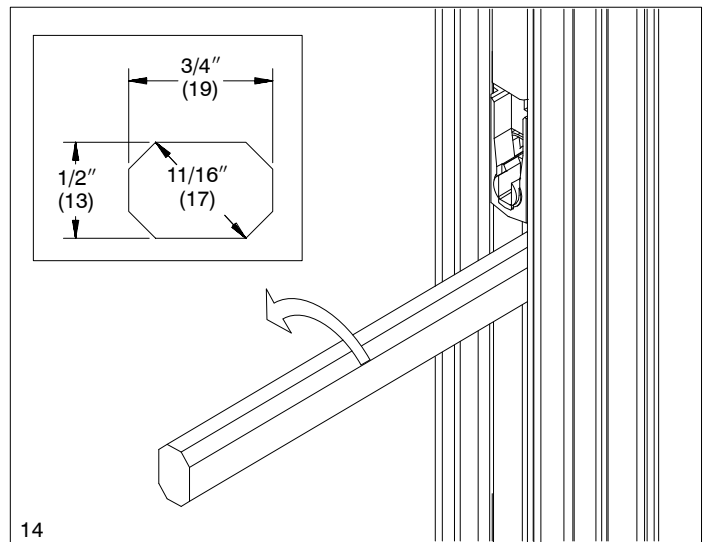
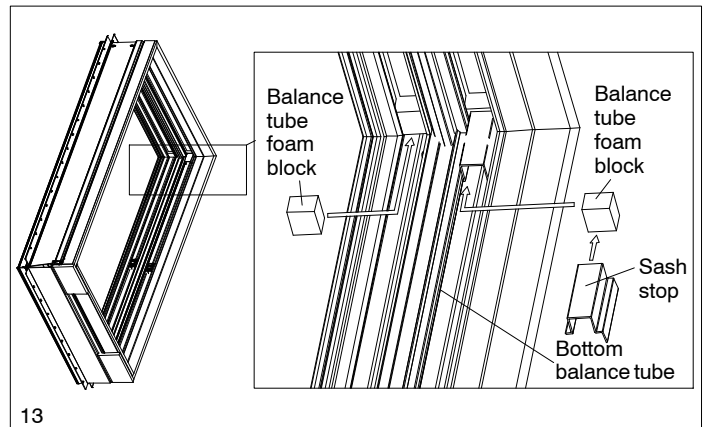
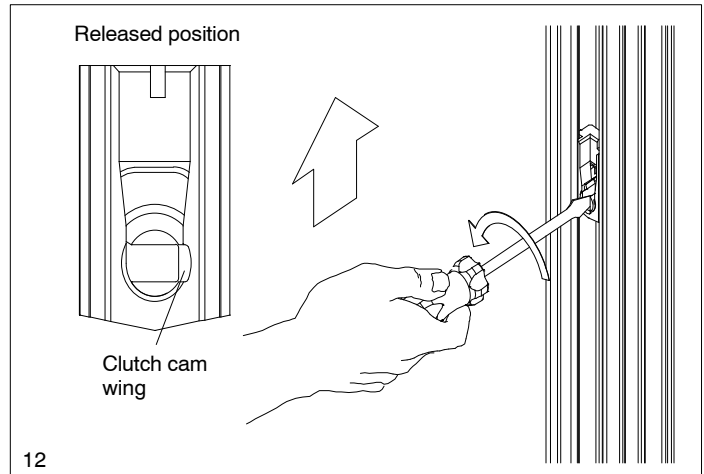

5. Insert screwdriver into the cam and rotate clutch assembly toward the exterior so that one side clears the operating channel. Remove clutch assembly from operating channel. See illustration 15.
6. Firmly push balance tube assembly up toward the head jamb to release hanger clip from the jamb. See illustration 16.
7. Remove balance tube assembly from the operating channel.
8. Insert the new balance tube in the operating channel half way up the jamb. Slide the assembly upward against the head jamb and place the hanger clip in the jamb slot as shown in illustration 17. Check balance tube to ensure hanger clip has engaged with slot.

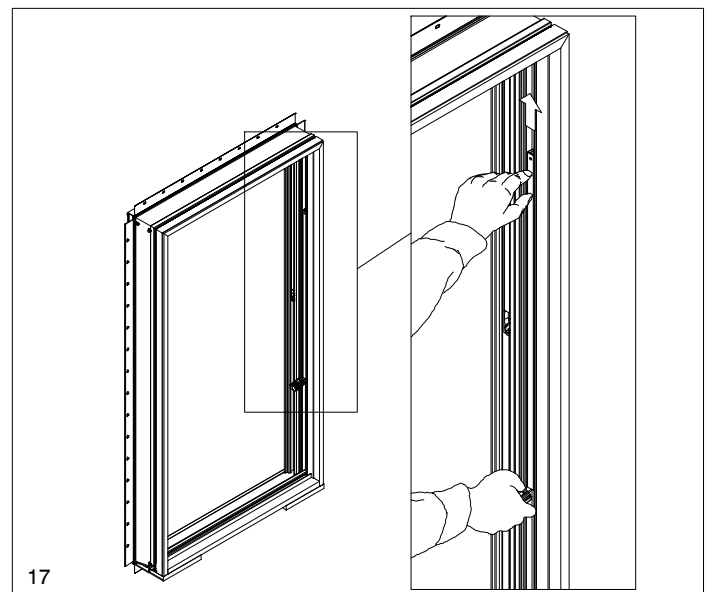
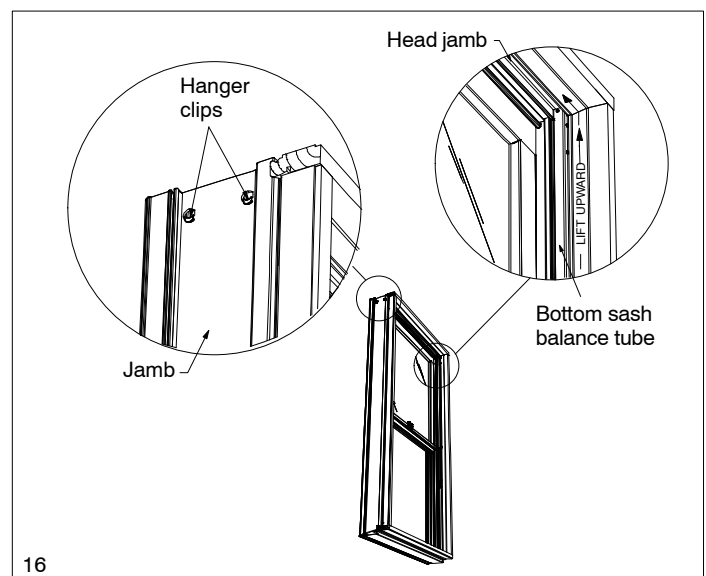
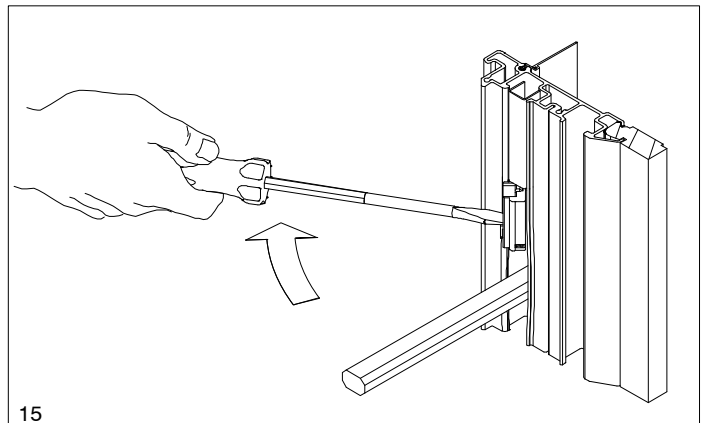

9. Position the clutch assembly for insertion into the operating channel. Using a flat screwdriver, rotate the clutch partly into the channel. See illustration 18.

NOTE: Before installing new balance tube assembly in the operating channel, make sure the clutch cam is in the released position (the wing of the cam should be to the interior of the jamb). See illustration 12.

10. Insert the screwdriver into the spring opening of the cam and (using the same rotating motion as before) pivot the clutch into position.
11. Place a pencil mark on the jamb 12" from the end of the balance tube. Insert the screwdriver into the cam and pull the clutch downward to the pencil mark. Using the screwdriver, rotate the cam into the locked position as shown in illustration 19. (The wing of the cam should be pointed down.) Repeat the same procedure for the opposing clutch.

NOTE: It is critical that opposing clutches are of equal distance from the bottom of the balance tube.

12. Replace balance tube foam block and sash stop.
13. Reinstall sash. (see Index, Installing Double Hung Sash).
14. Check sash operation. If any binding occurs during sash installation, stop immediately and make sure the sash pivot pins are completely engaged in the clutch cam.

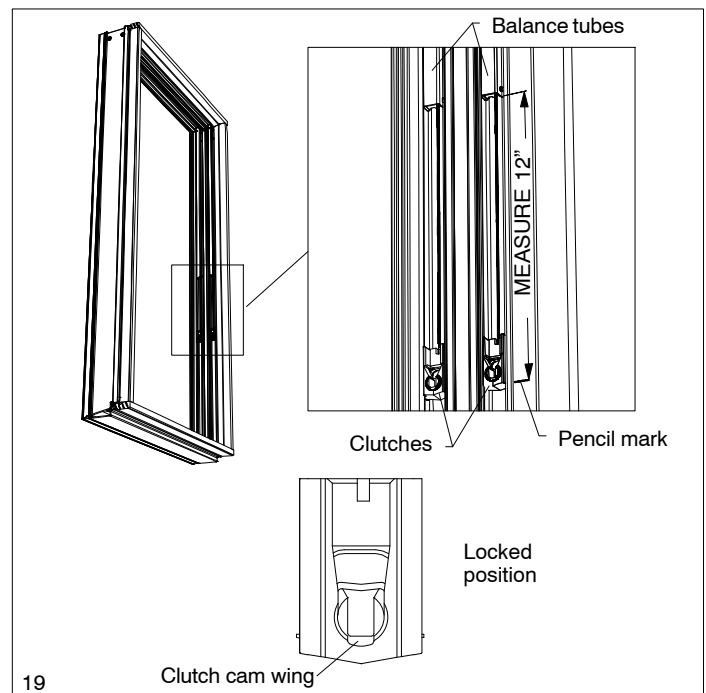
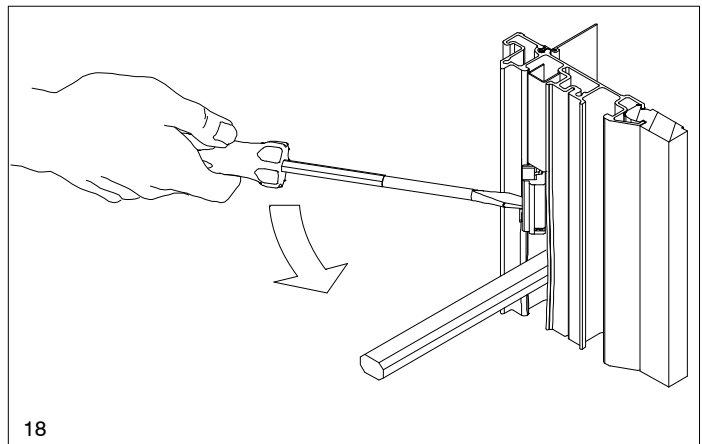

REPLACING SASH LOCKS

Tools needed: #2 Phillips screwdriver

Parts needed: Sash lock
#6x1 1/4" Phillips flathead wood screws

1. Remove the bottom sash. (see Index, Tilting or Removing Double Hung Sash).
2. Remove the two #6x1 1/4" Phillips flathead wood screws from the sash lock. See illustration 19.
3. Using the location of the old lock as a guide, install the new sash lock. Check to see that the wood screws are properly seated.
4. Replace the sash and check for proper operation. (see Index, Installing Double Hung Sash).

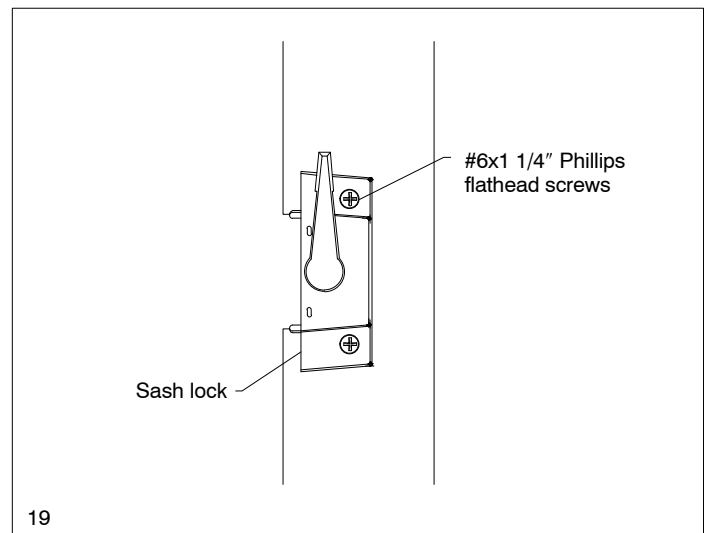

REPLACING SASH KEEPERS

Tools needed: #2 Phillips screwdriver

Parts needed: Sash keeper
#8x1" Phillips pan head screws

1. Remove the top and bottom sash (see Index, Tilting or Removing Double Hung Sash).
2. Remove the two #8x1" Phillips pan head screws from the sash keeper. See illustration 20.
3. Using the location of the old keeper as a guide, install the new keeper. Check to see that the wood screws are properly seated.
4. Replace both sash and check for proper operation. (see Index, Installing Double Hung Sash).

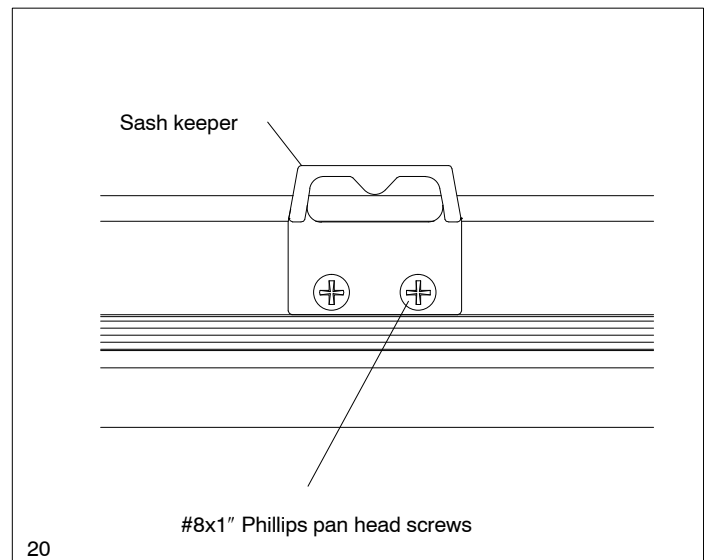

REPLACING TILT LATCHES

- Tools needed: #2 Phillips screwdriver
Parts needed: Tilt latch
#8x3/4" Phillips truss head screw

1. Remove the top and bottom sash (see Index, Tilting or Removing Double Hung Sash).
2. Remove the #8x3/4" Phillips truss head screw attaching the tilt latch to the top rail of the top sash. See illustration 21.
3. Using the location of the old tilt latch as a guide, install the new tilt latch.

NOTE: *Tilt latches are handed from the exterior. Make sure the correct tilt latch is being installed. Do not over tighten screws as tilt latches may not operate properly.*

4. Check new tilt latch to ensure smooth operation and adjust as necessary by tightening or loosening the screw.
5. Replace both sash (see Index, Installing Double Hung Sash).

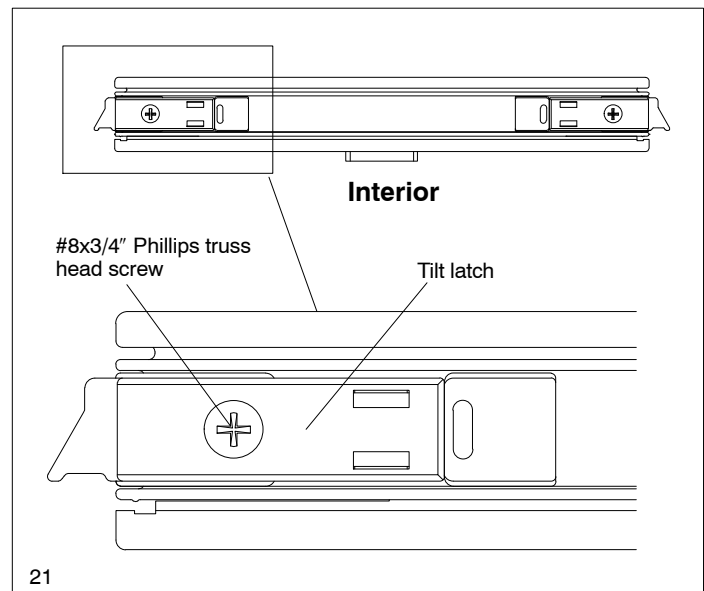

REPLACING TILT LATCH COVERS (BOTTOM SASH)

- Tools needed: #2 Phillips screwdriver
Parts needed: Tilt latch cover
#8x1" Phillips pan head screw

1. Remove bottom sash (see Tilting or Removing Double Hung Sash).
2. Remove the two #8x1" Phillips pan head screws attaching the tilt latch cover and tilt latch to bottom sash check rail. See illustration 22.
3. Place the new tilt latch cover over the tilt latch and replace screws.

NOTE: *Tilt latch covers are not handed. Do not over tighten as tilt latches may not operate properly.*

4. Check tilt latch to ensure smooth operation and adjust as necessary by tightening or loosening screws.
5. Replace sash (see Index, Installing Double Hung Sash).

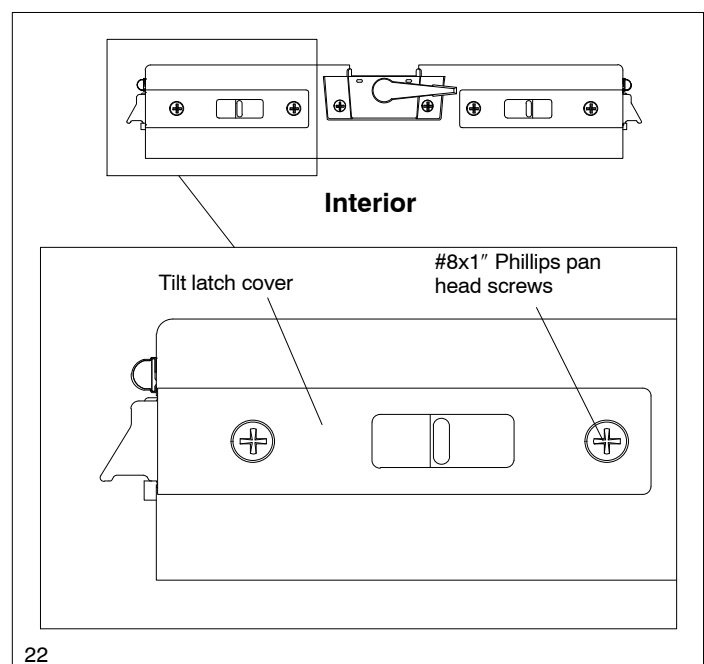

REPLACING SASH PIVOT PINS

Tools needed: #2 Phillips screwdriver

Parts needed: Sash pivot pin
#7x5/8" Phillips flathead screw

NOTE: Sash pivot pins are non-handed.

1. Remove sash (See Index, Tilting or Removing Double Hung Sash).
2. Remove the #7x5/8" Phillips flathead screw. See illustration 23.
3. Using the location of the old pivot pin as a guide, install the new pivot pin. Check to see that the screw is properly seated.
4. Replace the sash (see Index, Installing Double Hung Sash).
5. Check for proper sash operation.

